

LM2483

180V Triple Bias Clamp

General Description

The LM2483 driver is an Integrated 180V triple bias clamp circuit for DC recovery of each of the AC coupled outputs of a HDTV CRT driver. It is well matched with the DAC outputs of the LM126X family of pre-amplifiers. Each amplifier has its gain internally set to -30. The LM2483 is packaged in an industry standard 14 lead molded plastic dual-in-line package.

Features

- Wide range integrated triple bias clamp
- High input impedance

- Matched to LM2426 HDTV Driver

Applications

- AC coupled HDTV applications using the 1080i and 720p formats as well as standard NTSC and PAL formats.

Schematic and Connection Diagrams

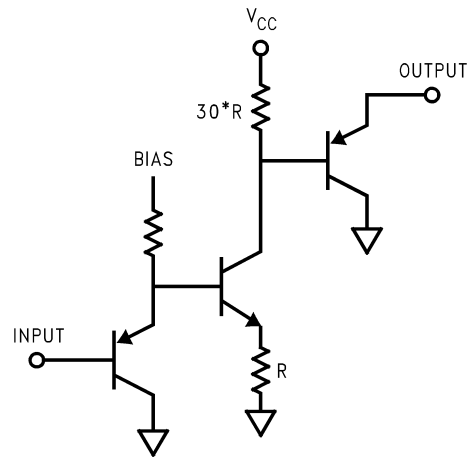
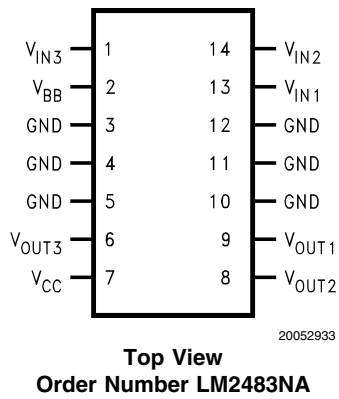

FIGURE 1. Simplified Schematic Diagram (One Channel)

Absolute Maximum Ratings (Notes 1,

3)

If Military/Aerospace specified devices are required, please contact the National Semiconductor Sales Office/Distributors for availability and specifications.

Supply Voltage, V_{CC}	+200V
Bias Voltage, V_{BB}	+15V
Input Voltage, V_{IN}	-0.5V to $V_{BB} + 0.5V$
Storage Temperature Range, T_{STG}	-65°C to +150°C
Lead Temperature (Soldering, <10sec.)	300°C
ESD Tolerance Machine Model	200V

Human Body Model	1.5 kV
Max Junction Temperature	150°C
θ_{JA} (Typ) (Note 5)	70°C

Limits of Operating Ranges (Note 3)

V_{CC}	130V to 180V
V_{BB}	7V to 13V
V_{IN}	1V to 5V
V_{OUT}	40V to 175V
Ambient Temperature Range, T_A	0°C to 70°C

DC Clamp Electrical Characteristics

(See Figure 2 for Test Circuit)

Unless otherwise noted: $V_{CC} = +180V$, $V_{BB} = 8V$, $V_{IN} = +2.5V$, $T_A = 30^\circ C$

Symbol	Parameter	Conditions	Min	Typ	Max	Units
I_{CC}	Supply Current	All three channels, includes 100K pull-up resistor current		4.5	7	mA
I_{BB}	Bias Supply Current	All channels		4		mA
V_{OUT}	DC Output Voltage		122	127	132	V_{DC}
$V_{OUT-Range}$	Output Voltage Range	V_{IN} Range = +1.5V to 4.5V		89		V
A_V	DC Voltage Gain		-27	-30	-33	V/V
LE	Linearity Error	See Note 4		5		%

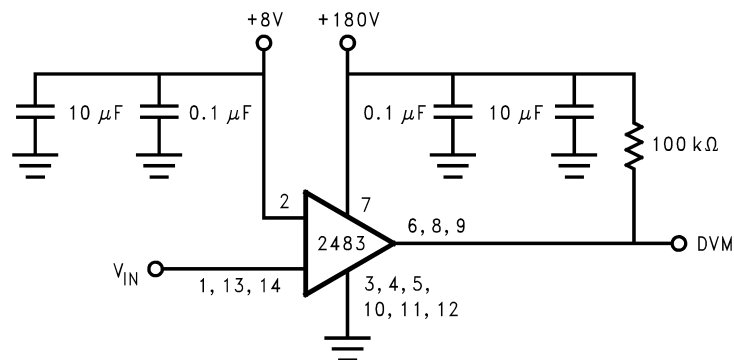
Note 1: Absolute Maximum Ratings indicate limits beyond which damage to the device may occur.**Note 2:** Operating Ratings indicate conditions for which the device is functional, but do not guarantee specific performance limits. For guaranteed specifications and the test conditions, see the Electrical Characteristics. Datasheet min/max specification limits are guaranteed by design, test, or statistical analysis. The guaranteed specifications apply only for the test conditions listed. Some performance characteristics may change when the device is not operated under the listed test conditions.**Note 3:** All voltages are measured with respect to GND, unless otherwise specified.**Note 4:** Linearity Error is the variation in dc gain from $V_{IN} = 1.5$ volts to $V_{IN} = 4.5$ volts.**Note 5:** Measured with 1in² copper on PCB connected to pins 3, 4, 5, 10, 11, 12. See Thermal Considerations Section.**Test Circuit**

20052934

FIGURE 2. Test Circuit

Figure 2 shows the test circuit for evaluation of the LM2483 Clamp Amplifier. A high impedance Voltmeter (>100M Ω) is used for DC measurements at the output.

Typical Performance Characteristics

($V_{CC} = +180V$, $V_{BB} = +8V$, $V_{IN} = +2.5V$, Test Circuit - Figure 2)

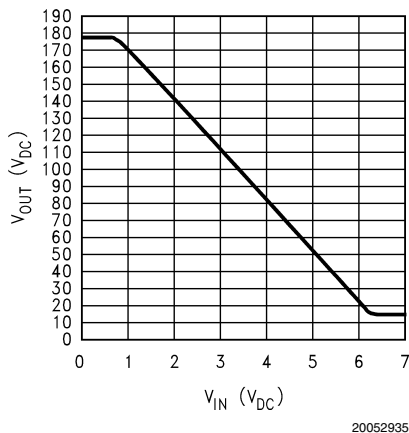

FIGURE 3. V_{out} vs V_{in}

Theory of Operation

The simplified circuit diagram of the LM2483 is shown in Figure 1. The DC clamp circuit amplifies the input signal by -30 and the gain is set by the resistor ratio of $30R$ and R . The output will require a pull-up resistor to 180V.

Figure 2 shows the test circuit for evaluation of the LM2483 Clamp Amplifier. A high impedance voltmeter ($>100M\Omega$) is used for DC measurements at the output.

Application Hints

INTRODUCTION

National Semiconductor (NSC) is committed to provide application information that assists our customers in obtaining the best performance possible from our products. The following information is provided in order to support this commitment. The reader should be aware that the optimization of performance was done using a specific printed circuit board designed at NSC. Variations in performance can be realized due to physical changes in the printed circuit board and the application. Therefore, the designer should know that component value changes may be required in order to optimize performance in a given application. The values shown in this document can be used as a starting point for evaluation purposes.

POWER SUPPLY BYPASS

The LM2483 should have proper power supply bypassing for optimum performance. A $0.1\ \mu F$ capacitor should be connected from the supply pins, V_{CC} and V_{BB} , to ground, as close to the supply and ground pins as is practical. Additionally, a $1\ \mu F$ electrolytic capacitor should be connected from the supply pins to ground. The electrolytic capacitor should also be placed reasonably close to the LM2483's supply and ground pins.

ARC PROTECTION

During normal CRT operation, internal arcing may occasionally occur. To protect the LM2483 against arcing the following steps should be done (See Figure 7):

- The traces connecting the LM126X preamp DACs and the LM2483 input pins (pins 1, 13, and 14) should be run around the top of the LM2426. They should not go through the output circuit of the LM2426.
- C43, C44, and C45 should be located close to the LM126X preamp.
- R44, R45, and R46 should be located close to the LM2483.
- C21, C24, and C25 on the output pins of the LM2483 (pins 6, 8, and 9) should be located close to the LM2483. The grounds of these capacitors should have a short direct return to GND (pins 3, 4, 5, 10, 11, and 12) of the LM2483.
- C9 and C36 on the supply lines (pins 2 and 7) should be located close to the LM2483. The grounds of these capacitors should have a short direct return to GND (pins 3, 4, 5, 10, 11, and 12) of the LM2483.
- The ground of the LM2483 should have a short direct connection to the ground of the LM2426.

Thermal Considerations

The package the LM2483 is in uses the ground pins (3, 4, 5, 10, 11, and 12) to conduct heat from the LM2483. These pins should be connected to a ground plane that acts as a heat sink. See the example ground plane connected to these pins in the National Semiconductor PCB shown in Figure 7.

Figure 4 is used to determine the size of ground plane heat sink. The lines in Figure 4 represent a junction temperature of $150^{\circ}C$ when the size of heat sink noted by the line is used. The area under the line is the safe operating area. Using Figure 4, the following example shows how to determine the size of the ground plane.

The LM2483 uses about 0.45W of quiescent power. If $V_{CC} = +180V$, and each channel of the LM2483 needs to sink an average of 1mA, the LM2483 will use:

$$0.45W + 3 \times (180V \times 1mA) = 0.99W$$

Figure 4 shows that the LM2483 dissipating 0.99W with one sq. in. of copper ground plane heat sink is in the safe operating range for any ambient temperature up to $70^{\circ}C$.

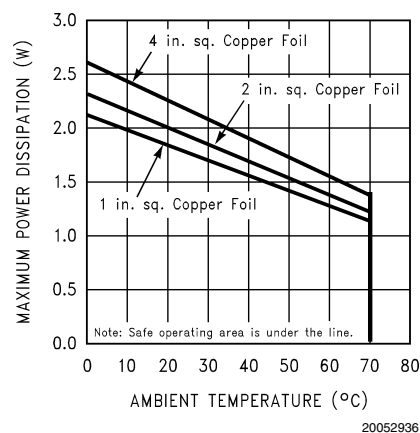

FIGURE 4. Maximum Power Dissipation vs. Ambient Temperature

Typical Application

A typical application of the LM2483 is shown in Figures 5 and Figure 6. Used in conjunction with an LM126X Preamp and an LM2426 CRT Driver, a complete video channel from input to CRT cathode can be achieved. Performance is ideal for HDTV applications. Figure 5 and Figure 6 are the schematic for the NSC demonstration board that can be used to evaluate the LM126X/LM2426/LM2483.

NSC Demonstration Board

Figure 7 shows the routing and component placement on the NSC LM126X/LM2426/LM2483 demonstration board. The schematic of the board is shown in Figure 5 and Figure 6. This board provides a good example of a layout that can be used as a guide.

Demonstration Board Schematics

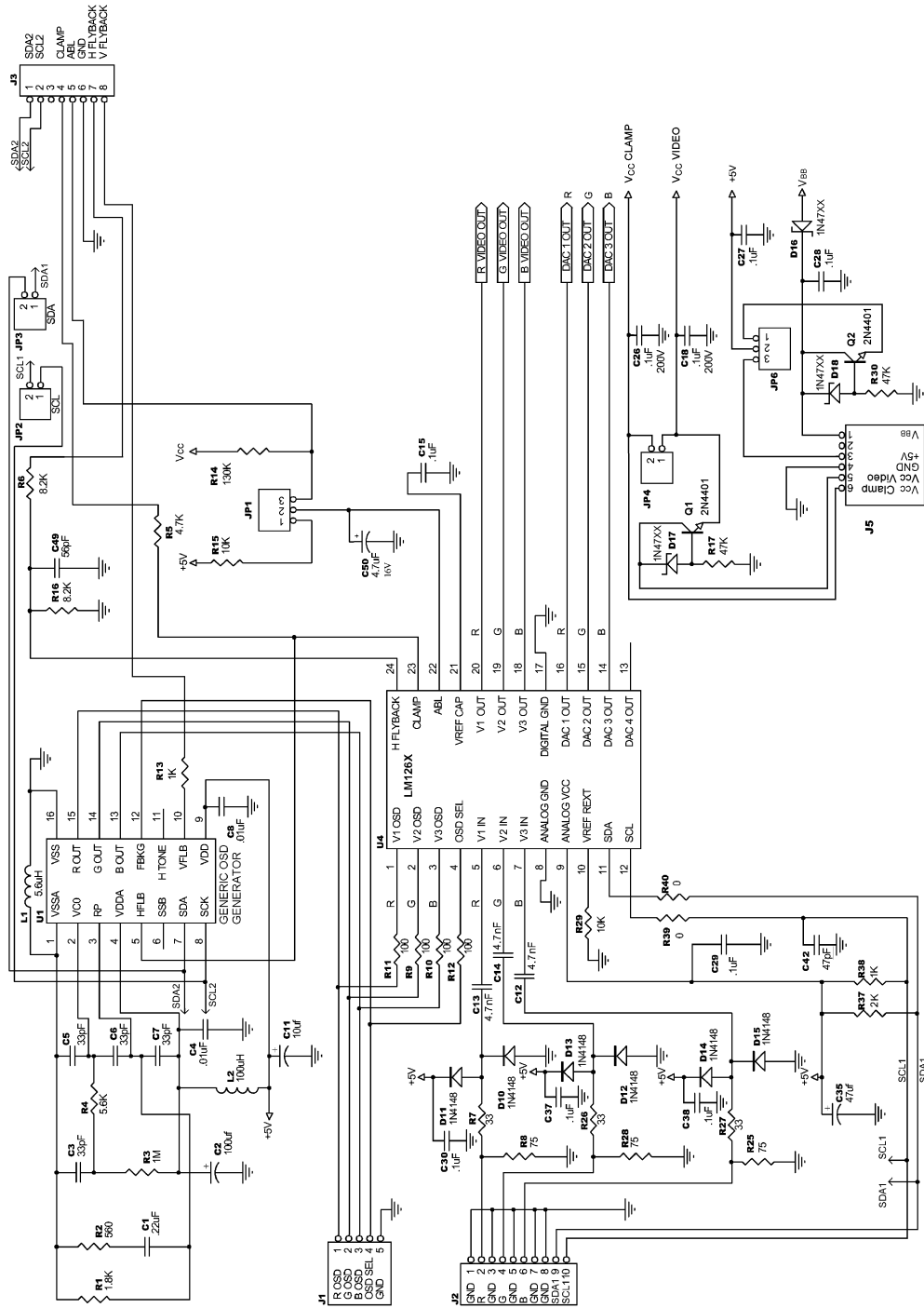

20052929

FIGURE 5. LM126X/LM2426/LM2483 Demonstration Board Schematic

Demonstration Board Schematics (Continued)

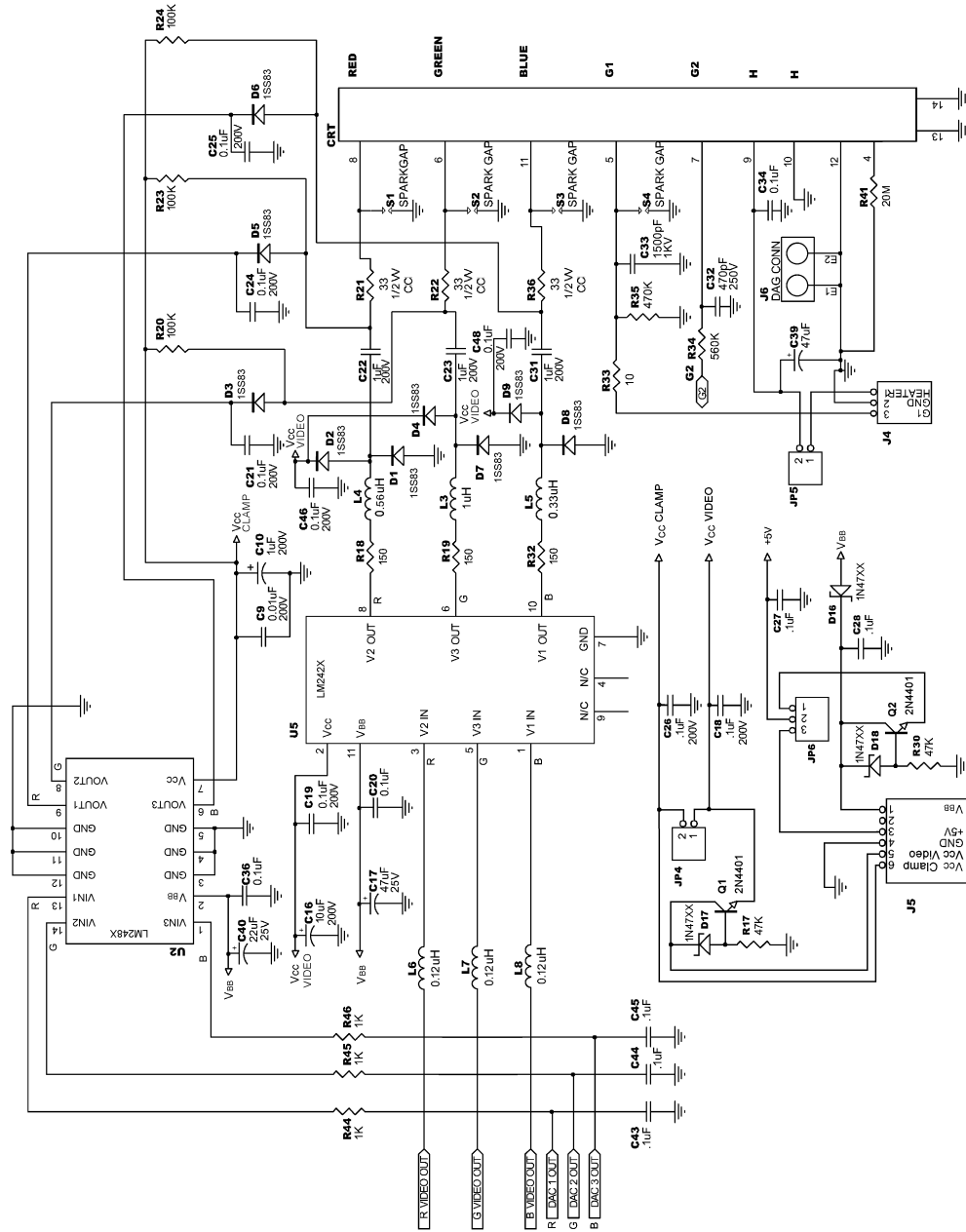

20052930

FIGURE 6. LM126X/LM2426/LM2483 Demonstration Board Schematic

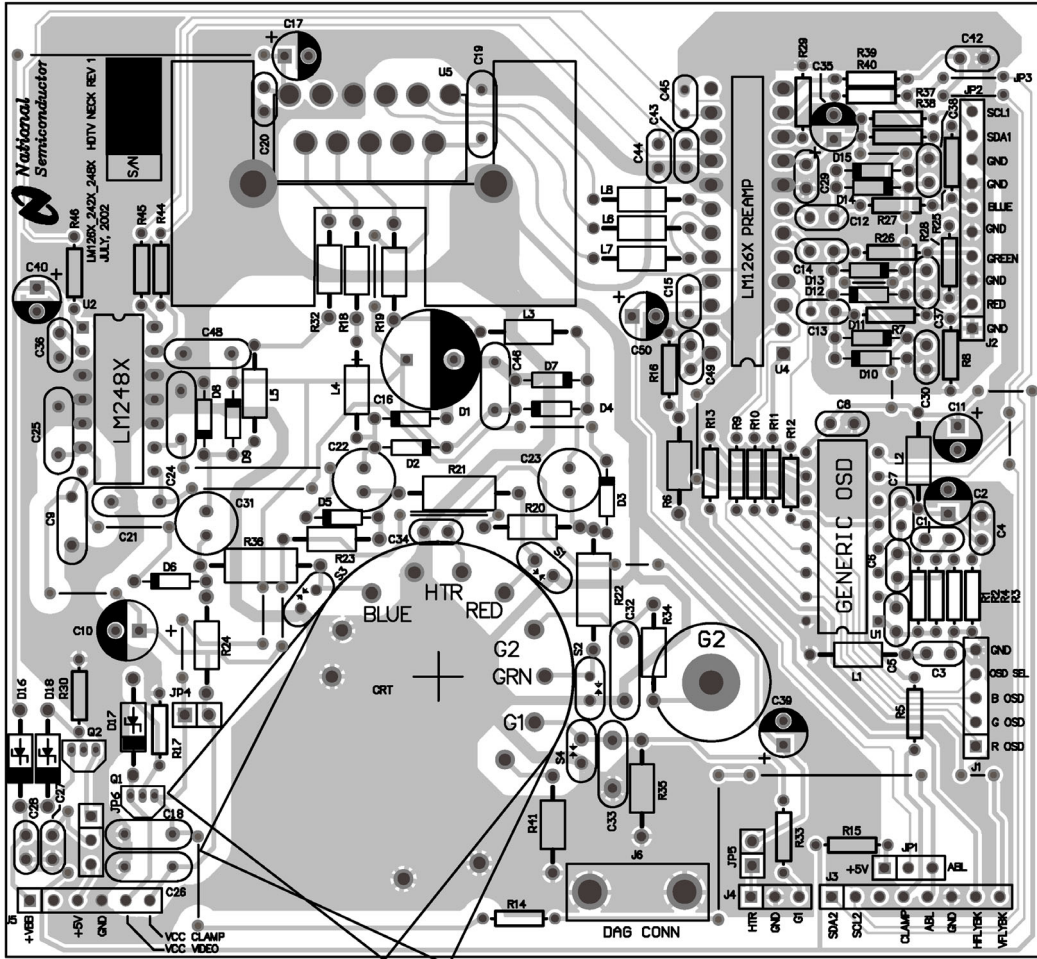
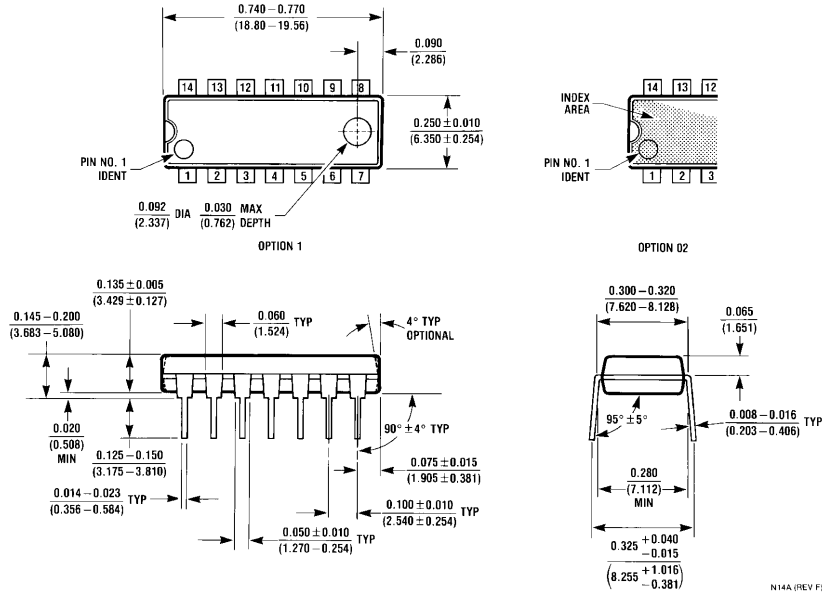

FIGURE 7. LM126X/LM2426/LM2483 Demonstration Board Layout

Physical Dimensions inches (millimeters)

unless otherwise noted



N14A (REV F)

Note: Information contained in this data sheet is preliminary and may be subject to change without notice.

Molded Dual-In-Line Package
Order Number LM2483NA
NS Package Number N14A

LIFE SUPPORT POLICY

NATIONAL'S PRODUCTS ARE NOT AUTHORIZED FOR USE AS CRITICAL COMPONENTS IN LIFE SUPPORT DEVICES OR SYSTEMS WITHOUT THE EXPRESS WRITTEN APPROVAL OF THE PRESIDENT AND GENERAL COUNSEL OF NATIONAL SEMICONDUCTOR CORPORATION. As used herein:

1. Life support devices or systems are devices or systems which, (a) are intended for surgical implant into the body, or (b) support or sustain life, and whose failure to perform when properly used in accordance with instructions for use provided in the labeling, can be reasonably expected to result in a significant injury to the user.
2. A critical component is any component of a life support device or system whose failure to perform can be reasonably expected to cause the failure of the life support device or system, or to affect its safety or effectiveness.



National Semiconductor Corporation
Americas
Email: support@nsc.com

www.national.com

National Semiconductor Europe
Fax: +49 (0) 180-530 85 86
Email: europe.support@nsc.com
Deutsch Tel: +49 (0) 69 9508 6208
English Tel: +44 (0) 870 24 0 2171
Français Tel: +33 (0) 1 41 91 8790

National Semiconductor Asia Pacific Customer Response Group
Tel: 65-2544466
Fax: 65-2504466
Email: ap.support@nsc.com

National Semiconductor Japan Ltd.
Tel: 81-3-5639-7560
Fax: 81-3-5639-7507