

LM1818 Electronically Switched Audio Tape System

General Description

The LM1818 is a linear integrated circuit containing all of the active electronics necessary for building a tape recorder deck (excluding the bias oscillator). The electronic functions on the chip include: a microphone and playback preamplifier, record and playback amplifiers, a meter driving circuit, and an automatic input level control circuit. The IC features complete internal electronic switching between the record and playback modes of operation. The multipole switch used in previous systems to switch between record and playback modes is replaced by a single pole switch, thereby allowing for more flexibility and reliability in the recorder design.*

Features

- Electronic record/play switching
- 85 dB power supply rejection
- Motional peak level meter circuitry
- Low noise preamplifier circuitry
- 3.5V to 18V supply operation
- Provision for external low noise input transistor

*Monaural operation, Figure 9.

Typical Applications

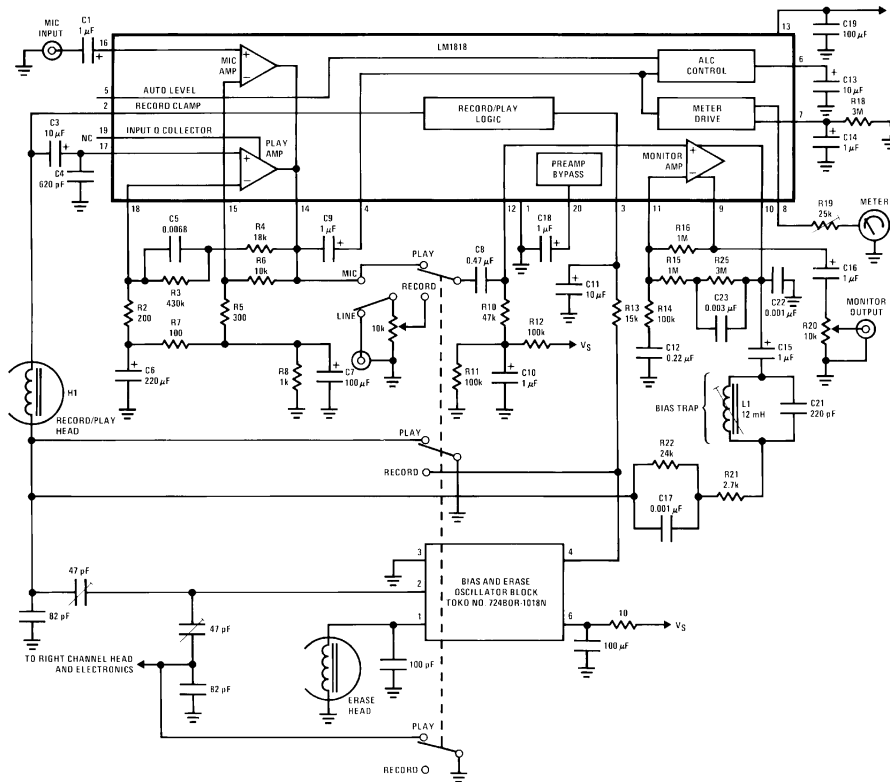

FIGURE 1. Stereo Application Circuit (Left Channel Shown), $V_S = 15V$

Order Number LM1818N
See NS Package Number N20A

TL/H/7894-1

LM1818 Electronically Switched Audio Tape System

Absolute Maximum Ratings

If Military/Aerospace specified devices are required, please contact the National Semiconductor Sales Office/Distributors for availability and specifications.

Supply Voltage	18V
Package Dissipation, (Note 1)	1560 mW
Storage Temperature	-65°C to +150°C

Operating Temperature	0°C to +70°C
Junction Temperature	150°C
Minimum Voltage on Any Pin	-0.1 V _{DC}
Maximum Voltage on Pins 2 and 5	0.1 V _{DC}
Maximum Current Out of Pin 14	5 mA _{DC}
Lead Temperature (Soldering, 10 sec.)	260°C

Electrical Characteristics

V_{CC} = 6V, T_A = 25°C, See Test Circuits (Figures 2 and 3)

Parameter	Conditions	Min	Typ	Max	Units
Operating Supply Voltage Range		3.5		18	V _{DC}
Supply Current	Test Circuit (Figure 2)		5	12	mA
Turn-ON Time	Externally Programmable	50	400		ms
Playback Signal to Noise	DIN Eq. (3180 and 120 μs), 20–20 kHz, R _S = 0, Unweighted, V _{REF} = 1 mV at 400 Hz		74		dB
Record Signal to Noise	Flat Gain, 20–20 kHz, R _S = 0, ALC OFF, V _{REF} = 1 mV at 1 kHz, Unweighted		69		dB
Fast Turn-ON Charging Current	Pins 16 and 17		200		μA
Record and Playback Preamp Input Open Loop Voltage Gain	f = 100 Hz		100		dB
Preamp Input Impedance	Pin 16 or Pin 17		50		kΩ
Preamp Input Referred PSRR	1 kHz — Flat Gain		85		dB
Bias Voltage on Pin 18 in Play Mode or Pin 15 in Record Mode			0.5		V
Monitor Amplifier Input Bias Current	Pins 11 and 12		0.5		μA
Monitor Amplifier Open Loop Voltage Gain	Record or Playback, f = 100 Hz		80		dB
Monitor Output Current Capability	Pins 9 and 10, Source Current Available	400	750		μA
Monitor Amplifier Output Swing	R _L = 10k, AC Load	1.2	1.65		V _{rms}
THD, All Amplifiers	At 1 kHz, 40 dB Closed Loop Gain		0.05		%
Record-Playback Switching Time	As in Test Circuit		50		ms
Input ALC Range	ΔV _{IN} for ΔV _{OUT} = 8 dB		40		dB
Input Voltage on ALC Pin for Start of ALC Action			25		mV _{rms}
ALC Input Impedance			2		kΩ
ALC Attack Time	C13 = 10 μF		7		ms
ALC Decay Time	R17 = ∞, C13 = 10 μF		30		sec
Meter Output Gain	100 mV _{rms} at 1 kHz into Pin 4		800		mV _{DC}
Meter Output Current Capability		2			mA _{DC}

Note 1: For operation in ambient temperatures above 25°C, the device must be derated based on a 150°C maximum junction temperature and a thermal resistance of 80°C/W junction to ambient.

Test Circuits

TL/H/7894-2

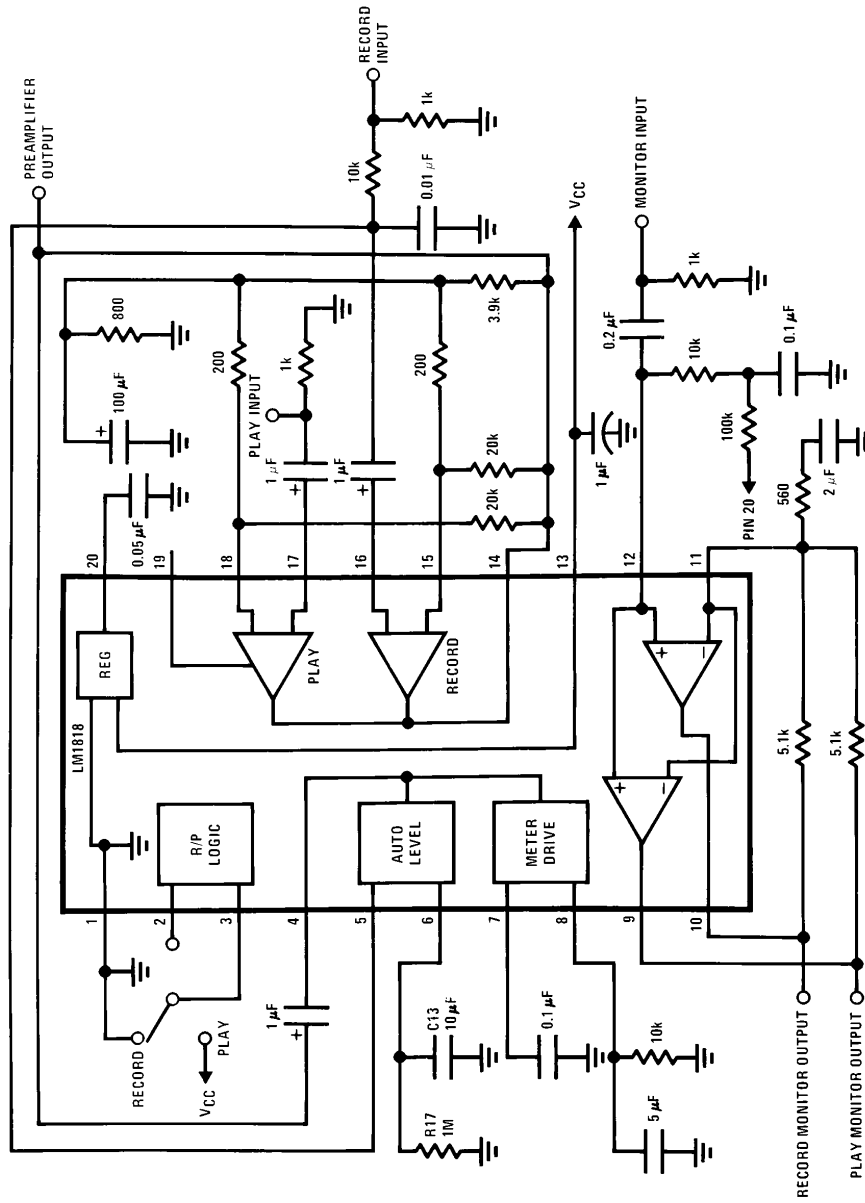

FIGURE 2. General Test Circuit

Test Circuits (Continued)

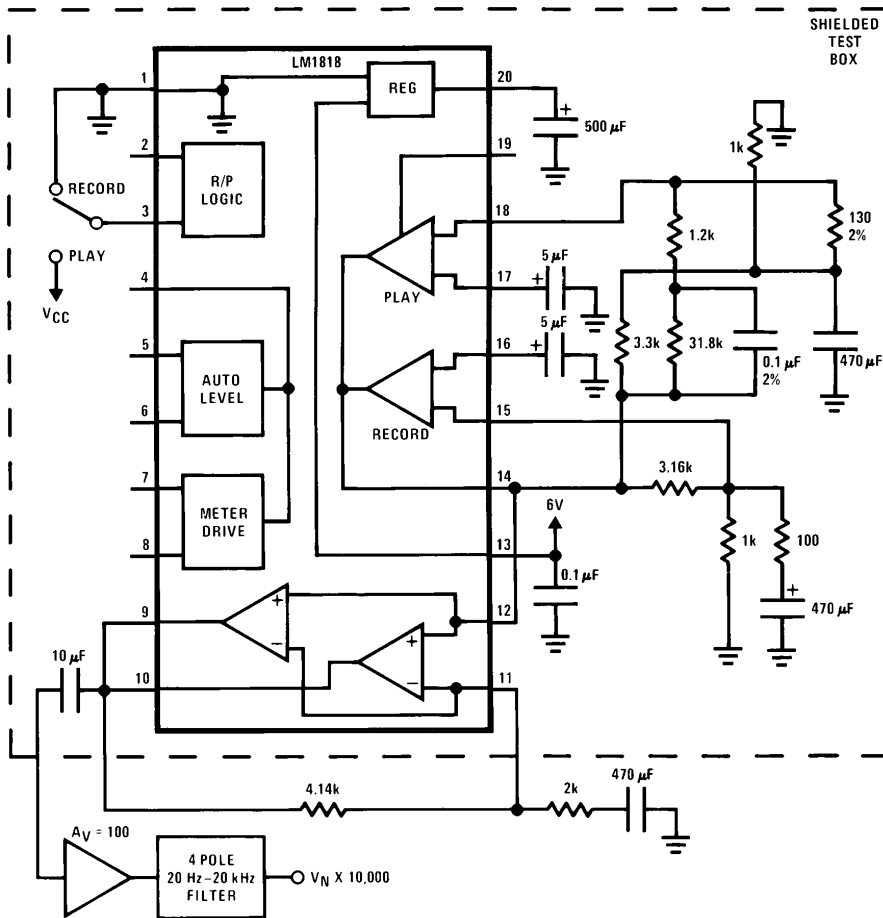

FIGURE 3. Noise Test Circuit

TL/H/7894-3

Equivalent Schematic Diagram

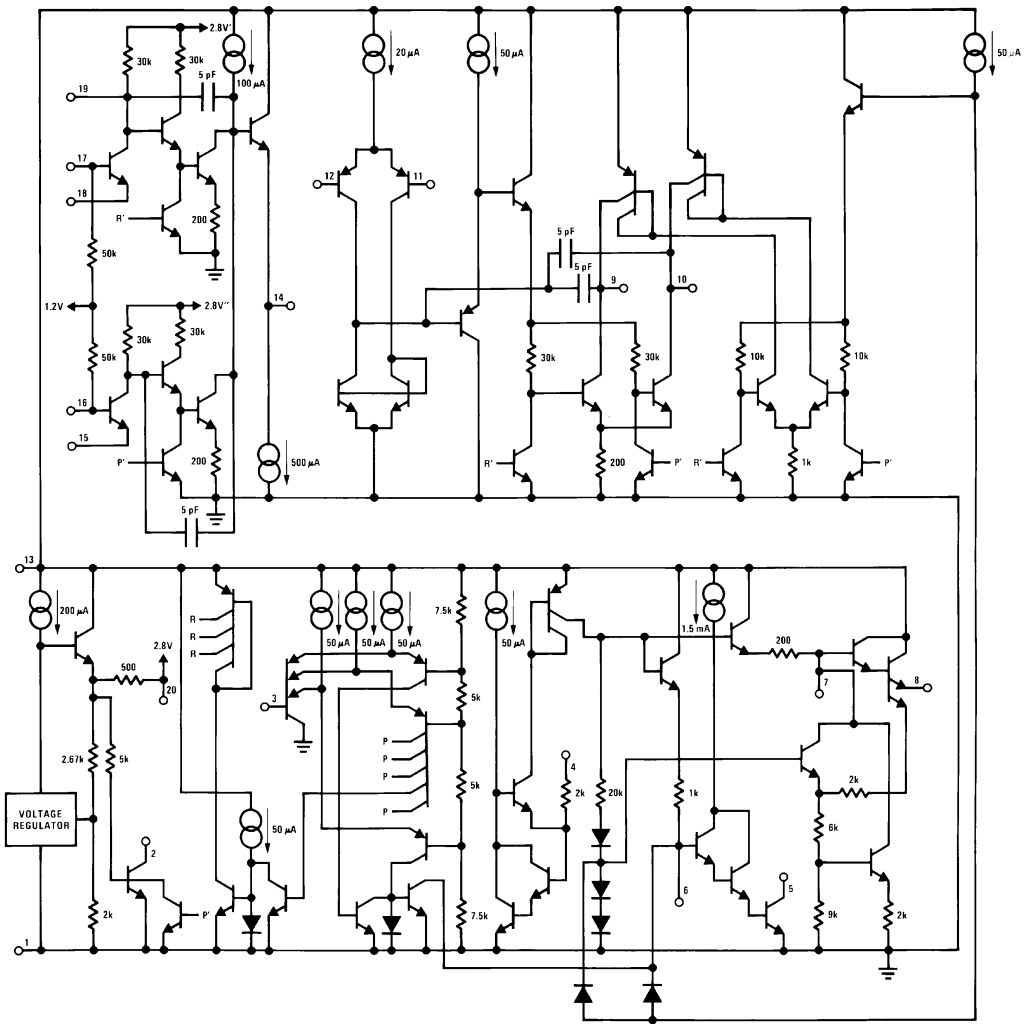
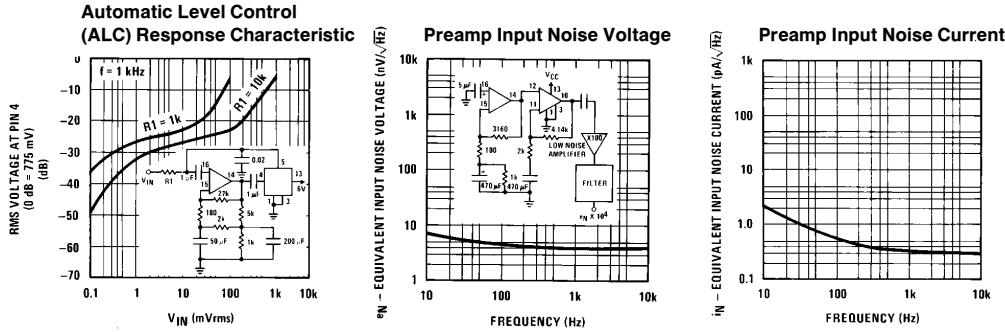

FIGURE 4

TL/H/7894-4

Typical Performance Characteristics



TL/H/7894-5

Application Hints

PREAMPLIFIERS (Figure 5)

There are 2 identical preamplifiers with 1 common output pin on the IC. One amplifies low level inputs such as a microphone in the record mode and another amplifies the signal from the playback head in the playback mode. The amplifiers use a common capacitor, C6, to set the low frequency pole of the closed loop responses. On the playback amplifier, the collector of the input device is made available so that an external low noise device can be connected in critical applications. When using an external low noise transistor, pins 17 and 18 of the IC are shorted together to ensure that the internal input transistor is turned OFF and the external transistor's collector is tied to pin 19. The input and feedback connections are now made to the external input

transistor. The amplifiers are stable for all gains above 5 and have a typical open loop gain of 100 dB. R8 and R9 enable C6 to be quickly charged and set the DC gain. Internal biasing provides a DC voltage independent of temperature at pin 17 so that the preamplifier DC output will remain relatively constant with temperature. Supply decoupling is provided by an internal regulator. Additional decoupling can be added for the input stages by increasing the size of the capacitor on pin 20 of the IC. A fast charging circuit is connected to the preamplifiers' input capacitors (pins 16 and 17) to decrease the turn-ON time. Larger input capacitors decrease the noise by reducing the source impedance at lower frequencies where $1/f$ noise current produces an input noise voltage. The input resistance of the preamplifiers is typically 50 k Ω .

Quiescent DC Output Voltage

$$V_{DC} = \left(1 + \frac{R9}{R8}\right) (0.5 - 50 \times 10^{-6} R2) \text{ if } R2 + R3 > 10 R_E$$

$$\text{where } R_E = \frac{R8R9}{R8 + R9}$$

AC Voltage Gain

$$A_{AC} = \frac{R4 + \frac{R3}{1 + sC5R3}}{R2} + 1$$

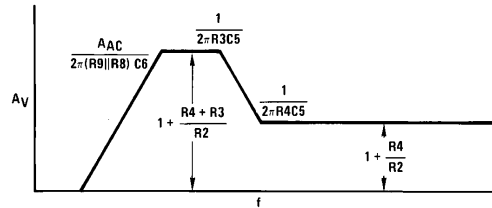

TL/H/7894-7

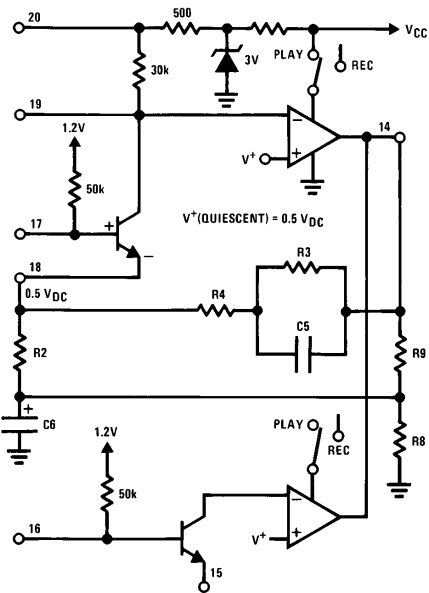

TL/H/7894-6

FIGURE 5. Preamplifier

Application Hints (Continued)

MONITOR AND RECORD AMPLIFIERS (Figure 6)

The monitor and record amplifiers share common input and feedback connections but have separate outputs. During playback, the input signal is amplified and appears only at the playback monitor output. Because the outputs are separate, different feedback components can be used and, as a result, totally different responses can be set. The amplifiers are stable for all closed loop gains above 3 and have an open loop gain of typically 80 dB. The outputs are capable of supplying a minimum of 400 μ A into a load and swing within 500 mV of either V_{CC} or ground. If more than 400 μ A is needed to drive a load, an external pull-up resistor on the output of these amplifiers can increase the load driving capability.

AUTOMATIC LEVEL CONTROL—ALC (Figure 7)

The automatic level control provides a constant output level for a wide range of record source input levels. The ALC works on the varying impedance characteristic of a saturat-

ed transistor. The impedance of the saturated transistor forms a voltage divider with the source impedance of a series resistor (R_1 in Figure 9). The input signal is decreased as the ALC transistor is increasingly forward biased. The ALC transistor will be forward biased when the preamplifier's AC output (pin 14), coupled to the combination ALC-meter drive input (pin 4) reaches 40 mV peak (25 mVrms). The gain of the ALC loop is such that a preamp input signal increase of 10 dB will result in a 2 dB increase on the AC output of the preamp. If greater than 25 mVrms is desired at the output of the preamp, a series resistor can be added between the preamp output coupling capacitor and the ALC input (pin 4). The input impedance of the ALC circuit is 2 k Ω ; therefore, if a 2 k Ω series resistor is added, ALC action will begin at 50 mVrms.

The ALC memory capacitor connected to pin 6 has the additional function of amplifier anti-pop control; for this reason, it is necessary that a capacitor be connected to pin 6 even if ALC is not used.

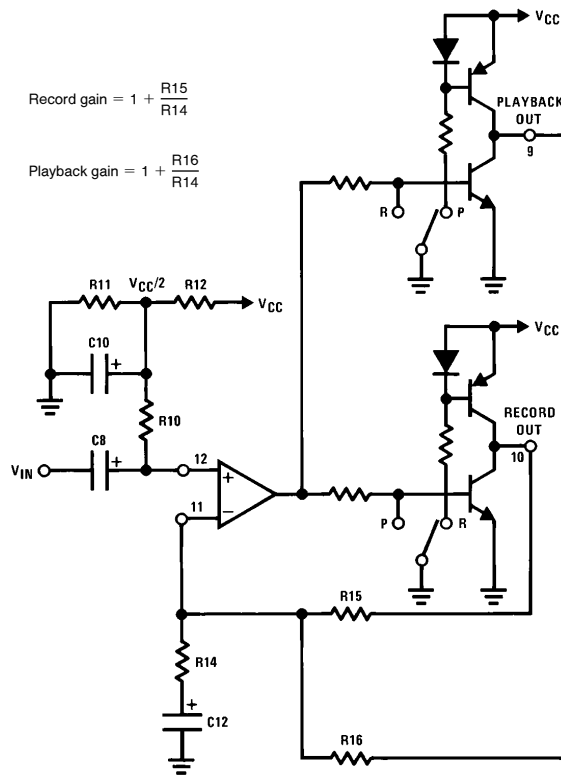

FIGURE 6. Monitor Amplifier

TL/H/7894-8

Application Hints (Continued)

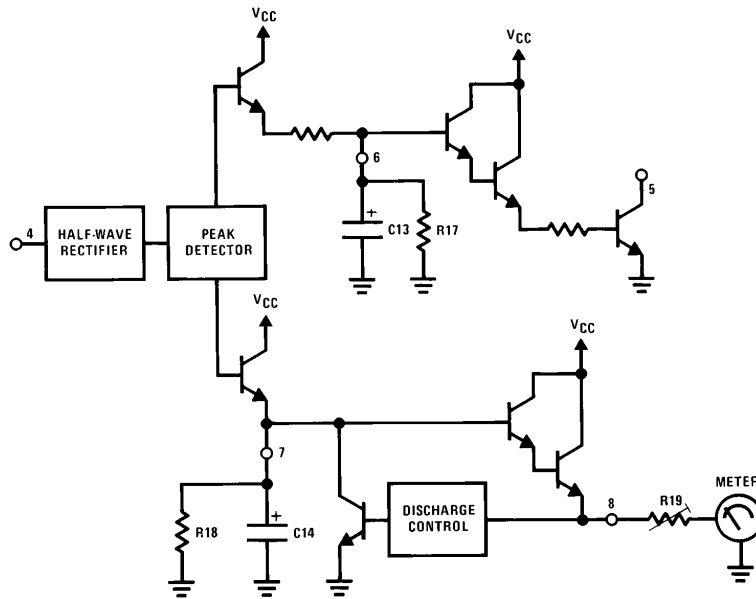

FIGURE 7. Auto Level-Meter Circuit

TL/H/7894-9

METER DRIVING—MOTIONAL PEAK LEVEL RESPONSE (Figure 7)

The meter drive output (pin 8) is capable of supplying 1–2 mA at a filtered DC voltage that is typically equal to 10 times the RMS value of the signal applied to the ALC-meter drive input (pin 4). The RC network connected to pin 7 of the IC determines the memory constant of the meter circuit. It is therefore possible to store the peak input signal by giving this RC network a long time constant, or read the instantaneous signal level by giving this RC network a very short time constant (i.e., no capacitor). This memory capacitor is discharged within the integrated circuit at a discharge rate related to the DC level on the meter output pin. When the

meter output pin is between 0 V_{DC} and 0.7 V_{DC} there is a 50 μA discharge current; when the pin is between 0.7V and 1.1V there is no internal discharge current; and when the voltage on pin 8 is greater than 1.1V there is a discharge equivalent to a 3.3k resistor across the memory capacitor. These different discharge rates allow the meter circuit to display fast, accurate responses on the lower portion of the meter display, slow responses in the higher portion of the meter display, and rapid discharge when the voltage is above the maximum reading the meter can display. The resistor in series with the meter can be adjusted such that the previously mentioned responses coincide with the proper points (0 VU and +3 VU) on the meter scale.

Application Hints (Continued)

Anti-Pop Circuitry (Figure 8)

The capacitor on pin 3 is used in a time delay system in conjunction with C13, the ALC capacitor, to suppress pops when switching between record and playback. Figure 8 illustrates how this is done. The output amplifier, either record or playback, is shut off prior to switching and carefully rebiased after switching takes place. It is therefore required that a proper ratio is selected between the ALC capacitor and the logic input RC time constant. The ALC capacitor must be discharged to 0.7V within the time it takes the logic input capacitor to: 1) charge from $V_{CC}/2$ to $0.7 V_{CC}$ when switching from record to playback, or 2) discharge from $V_{CC}/2$ to $0.3 V_{CC}$ when switching from playback to record. These times would normally be similar; however, the ALC capacitor can be charged to a different initial value depending upon the input to the ALC circuit. The maximum value to which the ALC memory capacitor will normally charge is 3.2V, therefore, the maximum time allowed for discharging C13 is given by:

$$t_1 = \frac{(C13 \times \Delta V)}{I_1} = C13 \frac{(3.2V - 0.7V)}{350 \mu A}$$

$$= C13 \times 7.2 \times 10^4$$

$$\text{If } C13 = 10 \mu F, t_1 = 72 \text{ ms}$$

It is now necessary to determine the minimum value for the R/P logic capacitor. This is done by computing the time between the 2 voltage switching points using the exponential equations for a single RC network.

$$t_2 = R13 C11 \ln \left[\frac{V_{CC}}{0.3 V_{CC}} \right] -$$

$$R13 C11 \ln \left[\frac{V_{CC}}{0.5 V_{CC}} \right] = 0.51 R13 C11$$

To be sure that C13 is completely discharged, let $t_2 > t_1$.

$$R13 C11 > \frac{t_1}{0.51} = \frac{(72 \text{ ms})}{0.51} = 141 \text{ ms}$$

$$\text{If } C11 = 10 \mu F, R13 = 15 \text{ k}\Omega$$

R13 should be kept to a value less than 50 k Ω to insure that bias current existing from pin 3 does not cause an offset voltage above 200 mV. Typically this bias current is less than 3 μA .

Record Playback Switch

When the voltage on pin 3 of the IC is greater than $0.5 V_{CC}$, the internal record-playback switch switches into the playback mode. During playback the record preamplifier remains partially biased but the input signal to this preamp does not appear at the preamplifier output. In addition, during the playback mode, the record monitor output (pin 9) is disabled and the ALC circuit operates to minimize the signal into the record preamp input. The meter circuit is operational in the playback as well as the record mode. Similarly, during the record mode, the playback preamp input is ignored and the playback monitor output is disabled. In addition, a pin is available to hold one side of the record head at ground potential while sinking up to 500 μA of AC bias and record current.

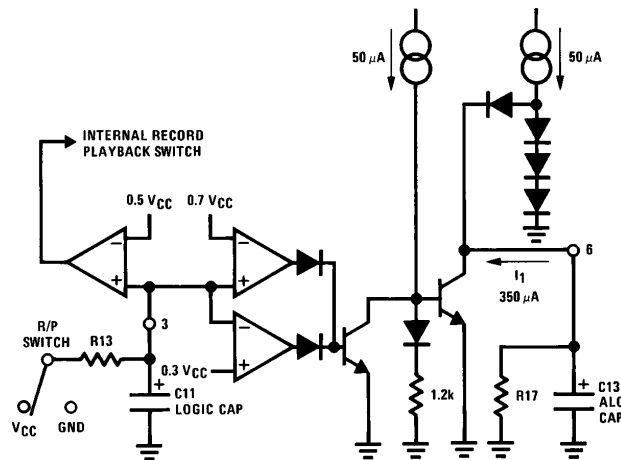

FIGURE 8A. Anti-Pop Circuit

TL/H/7894-10

Application Hints (Continued)

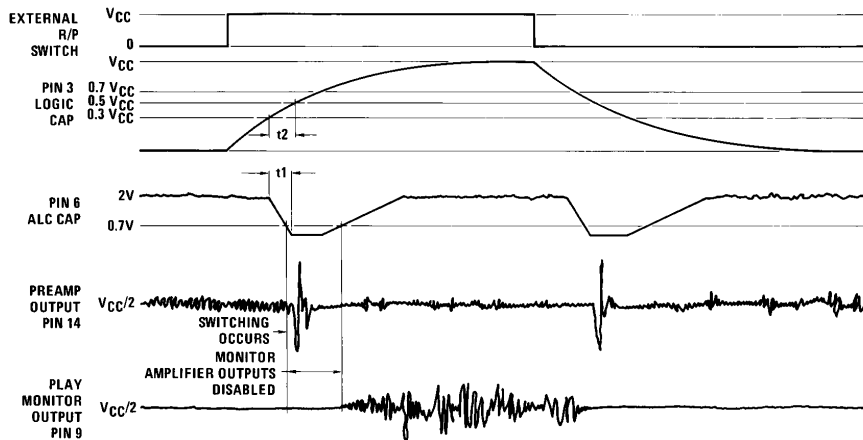

FIGURE 8B. Waveform for Anti-Pop Circuit

TL/H/7894-11

External Components (Refer to Figure 9, Monaural Application Circuit)

Component	External Component Function	Normal Range of Value
R1	Used in conjunction with varying impedance of pin 5, forming a resistor divider network to reduce input level in automatic level control circuit.	500 Ω –20 k Ω
C2	Forms a noise reduction system by varying bandwidth as a function of the changing impedance on pin 5. With a small input signal, the bandwidth is reduced by R1 and C2. As the input level increases, so does the bandwidth.	0.01 μ F–0.5 μ F
C1, C3	Coupling capacitors. Because these are part of the source impedance, it is important to use the larger values to keep low frequency source impedance at a minimum.	0.5 μ F–10 μ F
C4	Radio frequency interference roll-off capacitor	100 pF–300 pF
R2 R3 R4 C5	Playback response equalization. C5 and R3 form a pole in the amplifier response at 50 Hz. C5 and R4 form a zero in the response at 1.3 kHz for 120 μ s equalization and 2.3 kHz for 70 μ s equalization.	50 Ω –200 Ω 47 k Ω –3.3 M Ω 2 k Ω –200 k Ω
R5 R6	Microphone preamplifier gain equalization	50 Ω –200 Ω 5 k Ω –200 k Ω
R7 R8 R9 C6 C7	DC feedback path. Provides a low impedance path to the negative input in order to sink the 50 μ A negative input amplifier current. C6, R9, R7 and C7 provide isolation from the output so that adequate gain can be obtained at 20 Hz. This 2-pole technique also provides fast turn-ON settling time.	0–2 k Ω 200 Ω –5 k Ω 1 k Ω –30 k Ω 200 μ F–1000 μ F 0–100 μ F
C8	Preamplifier output to monitor amplifier input coupling	0.05 μ F–1 μ F
C9	ALC coupling capacitor. Note that ALC input impedance is 2 k Ω	0.1 μ F–5 μ F
R10 R11 R12 C10	These components bias the monitor amplifier output to half supply since the amplifier is unity gain at DC. This allows for maximum output swing on a varying supply.	10 k Ω –100 k Ω 10 k Ω –100 k Ω 10 k Ω –100 k Ω 1 μ F–100 μ F

External Components (Refer to Figure 9, Monaural Application Circuit) (Continued)

Component	External Component Function	Normal Range of Value
C11 R13	Exponentially falling or rising signal on pin 3 determines sequencing, time delay, and operational mode of the record/play anti-pop circuitry. See anti-pop diagram.	0–10 μ F 0–50 k Ω
R14 R15 R16 C12	R16, R14 and C12 determine monitor amplifier response in the play mode. R15, R14 and C12 determine monitor amplifier response in the record mode.	1k–100k 30 k Ω –3 M Ω 30 k Ω –3 M Ω 0.1 μ F–20 μ F
C13 R17	Determines decay response on ALC characteristic and reduces amplifier pop	5 μ F–20 μ F 100k– ∞
C14 R18	Determines time constant of meter driving circuitry	0.1 μ F–10 μ F 100k– ∞
R19	Meter sensitivity adjust	10 k Ω –100 k Ω
C15	Record output DC blocking capacitor	1 μ F–10 μ F
C16	Play output DC blocking capacitor	0.1 μ F–10 μ F
C17 R21 R22	Changes record output response to approximate a constant current output in conjunction with record head impedance resulting in proper recording equalization	500 pF–0.1 μ F 5 k Ω –100 k Ω 5 k Ω –100 k Ω
C18	Preamplifier supply decoupling capacitor. Note that large value capacitor will increase turn-ON time	0.1 μ F–500 μ F
C19	Supply decoupling capacitor	100 μ F–1000 μ F
C20	Decouples bias oscillator supply	10 μ F–500 μ F
R23	Allows bias level adjustment	0–1 k Ω
R24	Adjusts DC erase current in DC erase machines (for AC erase, see "Stereo Application Circuit," <i>Figure 1</i>)	
L1 C21	Optional bias trap	1 mH–30 mH 100 pF–2000 pF
C22	Bias Roll-Off	0.001 μ F–0.01 μ F
H1	Record/play head	100 Ω –500 Ω ; 70 mH–300 mH
H2	Erase head (DC type, AC optional)	10 Ω –300 Ω

Typical Applications (Continued)

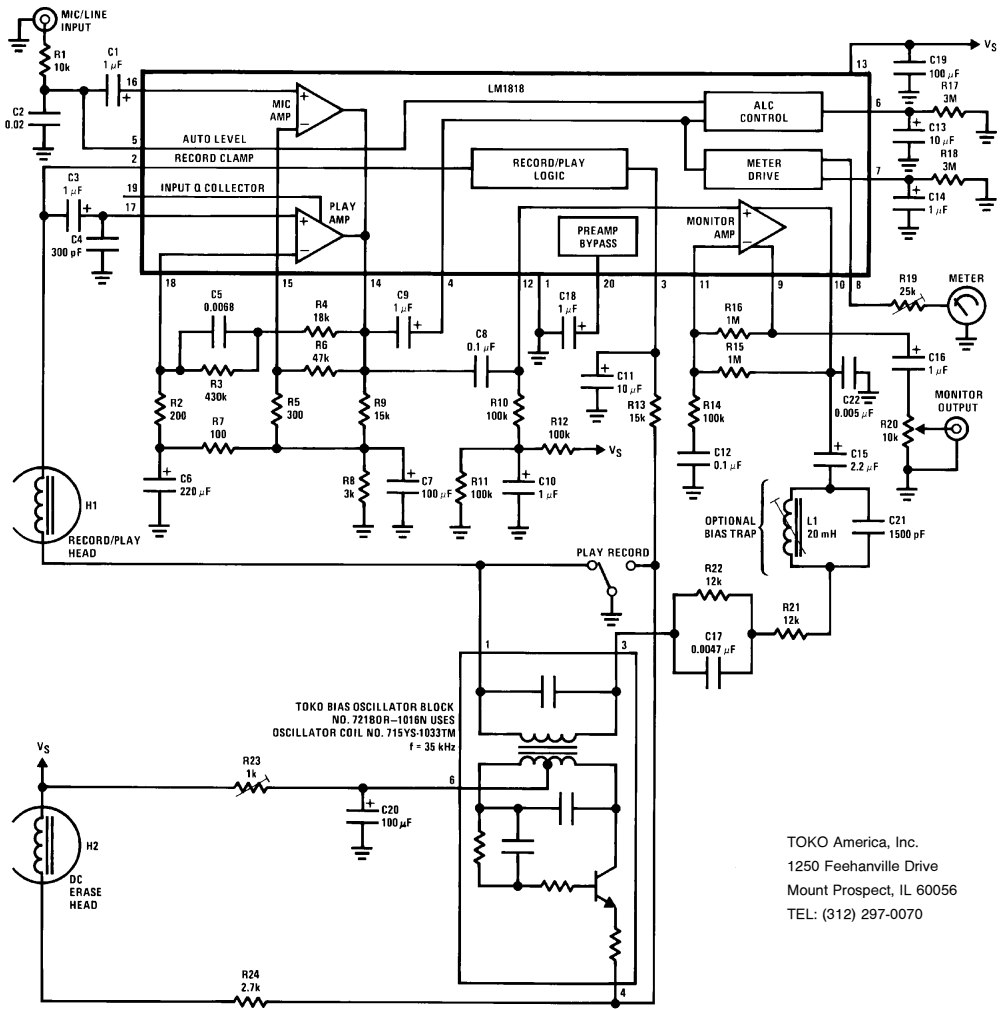

TOKO America, Inc.
 1250 Feehanville Drive
 Mount Prospect, IL 60056
 TEL: (312) 297-0070

FIGURE 9A. Monaural Application Circuit

TL/H/7894-12

Typical Applications (Continued)

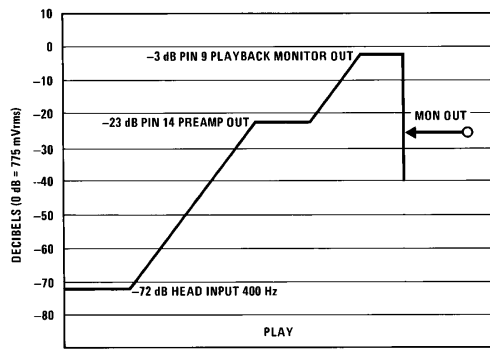

TL/H/7894-13

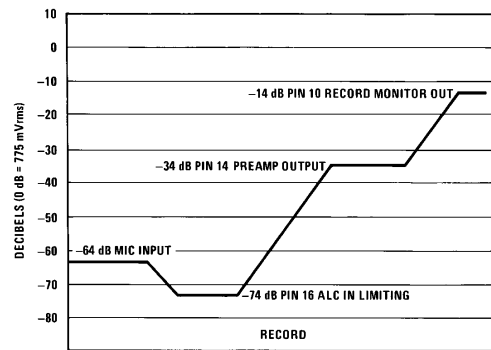

TL/H/7894-14

FIGURE 9B. Level Diagram for Monaural Application Circuit

Physical Dimensions inches (millimeters)

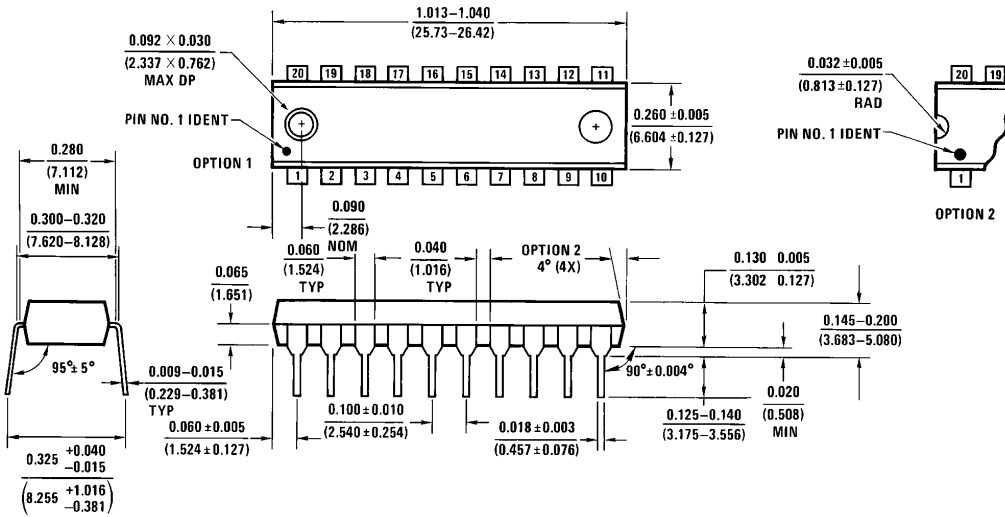

Molded Dual-In-Line Package (N)
Order Number LM1818N
NS Package Number N20A

N20A (REV G)

LIFE SUPPORT POLICY

NATIONAL'S PRODUCTS ARE NOT AUTHORIZED FOR USE AS CRITICAL COMPONENTS IN LIFE SUPPORT DEVICES OR SYSTEMS WITHOUT THE EXPRESS WRITTEN APPROVAL OF THE PRESIDENT OF NATIONAL SEMICONDUCTOR CORPORATION. As used herein:

1. Life support devices or systems are devices or systems which, (a) are intended for surgical implant into the body, or (b) support or sustain life, and whose failure to perform, when properly used in accordance with instructions for use provided in the labeling, can be reasonably expected to result in a significant injury to the user.
2. A critical component is any component of a life support device or system whose failure to perform can be reasonably expected to cause the failure of the life support device or system, or to affect its safety or effectiveness.



National Semiconductor Corporation
 1111 West Bardin Road
 Arlington, TX 76017
 Tel: 1(800) 272-9959
 Fax: 1(800) 737-7018

National Semiconductor Europe
 Fax: (+49) 0-180-530 85 86
 Email: cnjwge@tevm2.nsc.com
 Deutsch Tel: (+49) 0-180-530 85 85
 English Tel: (+49) 0-180-532 78 32
 Français Tel: (+49) 0-180-532 93 58
 Italiano Tel: (+49) 0-180-534 16 80

National Semiconductor Hong Kong Ltd.
 19th Floor, Straight Block,
 Ocean Centre, 5 Canton Rd.
 Tsimshatsui, Kowloon
 Hong Kong
 Tel: (852) 2737-1600
 Fax: (852) 2736-9960

National Semiconductor Japan Ltd.
 Tel: 81-043-299-2309
 Fax: 81-043-299-2408

National does not assume any responsibility for use of any circuitry described, no circuit patent licenses are implied and National reserves the right at any time without notice to change said circuitry and specifications.